

GPA-25 Palletizing Robot

with vacuum gripper

6-axis-robot for dynamic palletizing
and depalletizing on up to 2 pallets

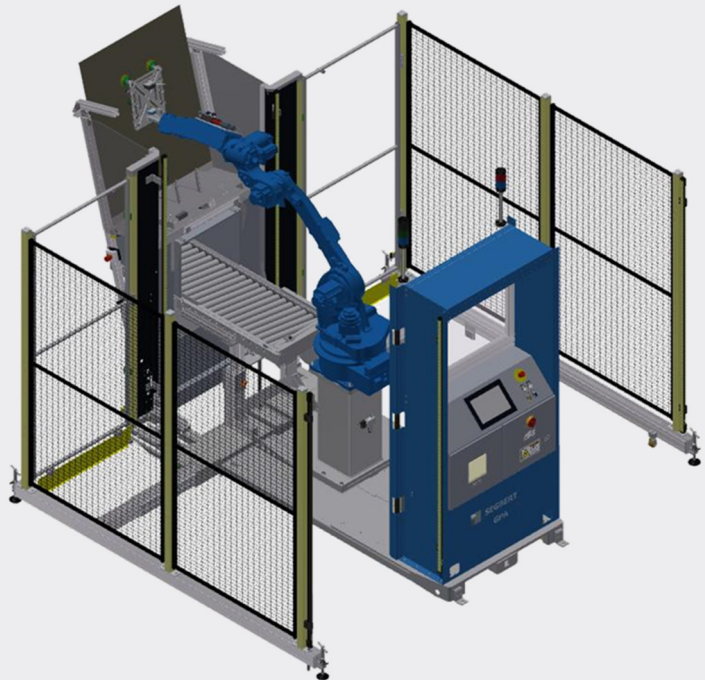

Technical Specifications

Products		Cardboard boxes, boxes, and other products that can be gripped with suction, Cardboard magazine optional
System		6-axis-robot
Product width		100 – 400 mm (optionally also bigger)
Product length		100 – 600 mm
Product height		50 – 400 mm (other heights on request)
Carrier capacity	max.	20 kg*
Pallet formats		800 x 1200 mm, 1000 x 1200 mm, 40 x 48", 1165 x 1165 mm, 45 x 45" (other pallet formats possible)
Pallet height	max.	approx. 1800 mm incl. pallet*
Empty pallet height		130 mm (min.) – 150 mm (max.)
Speed	max.	11 cycles/min.*
Drive		6 controlled Servo axes
Voltage		3 x 380 – 440 VAC, 50/60 Hz
Power consumption	approx.	3 kVA
Fuse		3 x 16 A, slow-blow fuse
Air pressure	min.	6 bar
Air consumption		depending on gripping device
Control		IPC with RobAdmin palletizing program as a configuration interface for setting the package and pallet sizes and layer patterns

*The data given is interdependent with product dimensions, pallet format, pallet height, speed, gripping tool, column height and number of slip sheets.

Color scheme as shown (see above).

SEGBERT

PALLETIZING & AUTOMATION

Gutenbergstraße 16
D-48683 Ahaus

Telefon +49 (0) 25 61 / 95 04-0
Telefax +49 (0) 25 61 / 95 04-20
Mail segbert@segbert.com

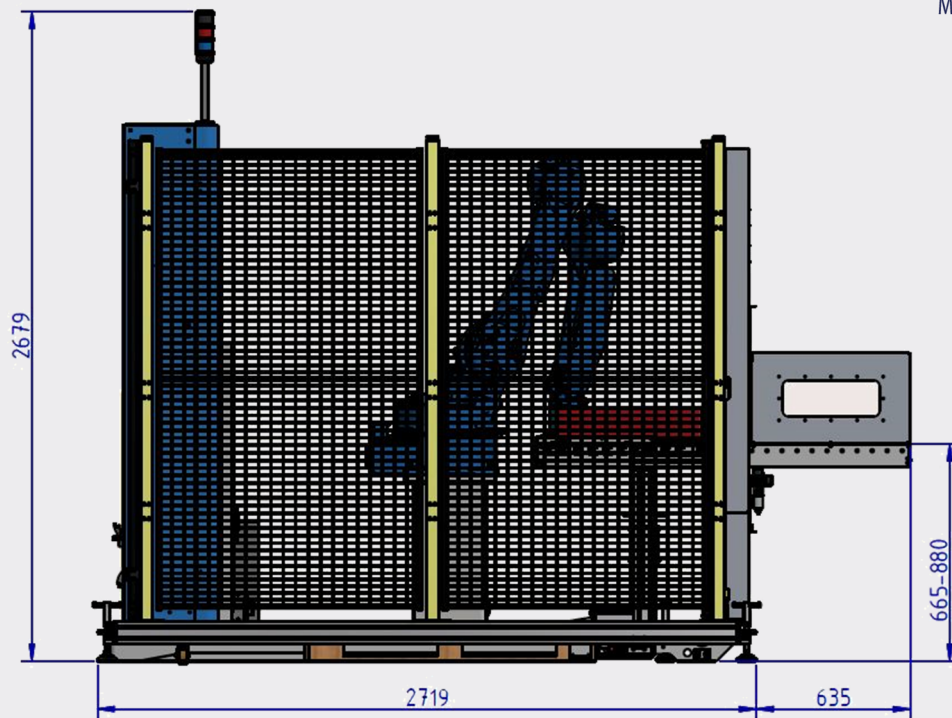

Transport dimensions

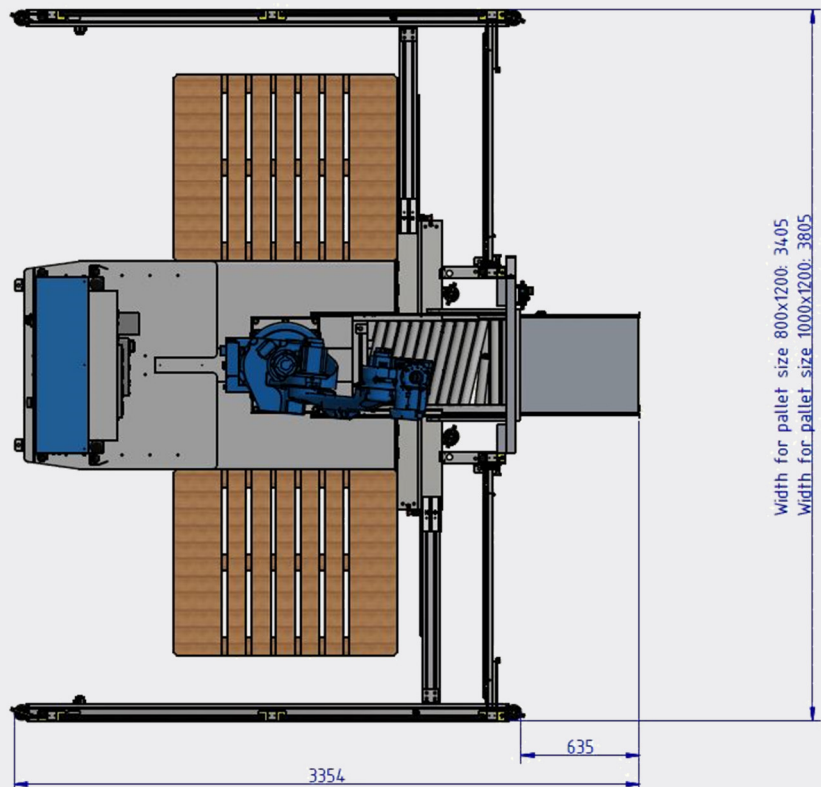
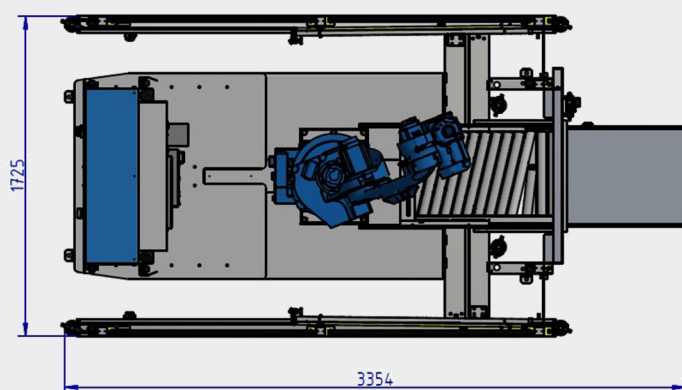

Volksbank Gronau Ahaus eG IBAN: DE33 4016 4024 0602 0192 00 BIC: GENODEM1GRN

Sitz der Gesellschaft: Ahaus Registergericht: Coesfeld, HRA 2848 UStID.: DE123788344 Steuernummer: 301/5750/0035

Komplementär: Segbert Verwaltungsgesellschaft mbH Sitz: Ahaus Registergericht: Coesfeld, HRB 4251

Geschäftsführer: Klaus Segbert